



RoHS Compliant and Pb-Free Product
Package: S-20



Features

- Frequency Range 5 –250 MHz
- Low Cost and **RoHS** Compliant
- Flux Coupled
- Industry Standard SMT package
- Available in Tape-and -Reel
- 75 Ohms Characteristic Impedance

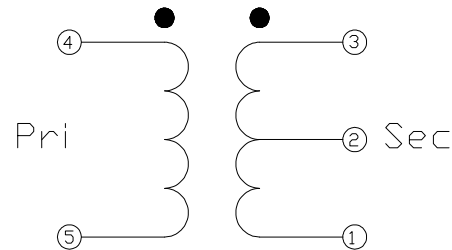

Schematic

Applications

- Broadband
- Wireless Communications

Product Description

The RFXF2753 Transformer is designed for applications that require very small, low cost, and highly reliable surface mount components. Applications may be found in broadband, wireless and other communications systems. These units are built Lead-Free and RoHS compliant and feature welded wire construction for increased reliability. S-Parameters are available on request.

Specifications

Parameter	Min.	Typ.	Max.	Unit	Condition
Typical values represent Mid-Band performance at 25 °C					
Frequency Range	5		250	MHz	
Insertion Loss		0.85	1.0	dB	
Amplitude Balance		0.1	0.2	dB	
Phase Balance		0.5	1.0	°	
Input Return Loss	15	18		dB	
Impedance Ratio	1:4				
Type	Unbalanced to Balanced				

Absolute Maximum Ratings

Parameter	Rating	Unit
RF Power	2	Watt
Operating Temperature	-40 to +100	°C
Storage Temperature	-55 to +100	°C



Caution! ESD sensitive device.

Exceeding any one or a combination of the Absolute Maximum Rating conditions may cause permanent damage to the device. Extended application of Absolute Maximum Rating conditions to the device may reduce device reliability. Specified typical performance or functional operation of the device under Absolute Maximum Rating conditions is not implied.

RoHS status based on EUDirective2002/95/EC (at time of this document revision).

The information in this publication is believed to be accurate and reliable. However, no responsibility is assumed by RF Micro Devices, Inc. ("RFMD") for its use, nor for any infringement of patents, or other rights of third parties, resulting from its use. No license is granted by implication or otherwise under any patent or patent rights of RFMD. RFMD reserves the right to change component circuitry, recommended application circuitry and specifications at any time without prior notice.

Typical Data

Return Loss

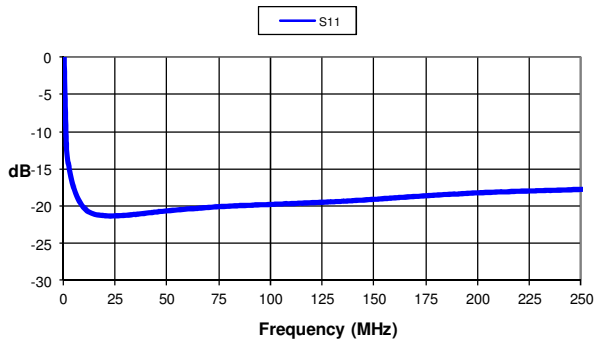

Insertion Loss

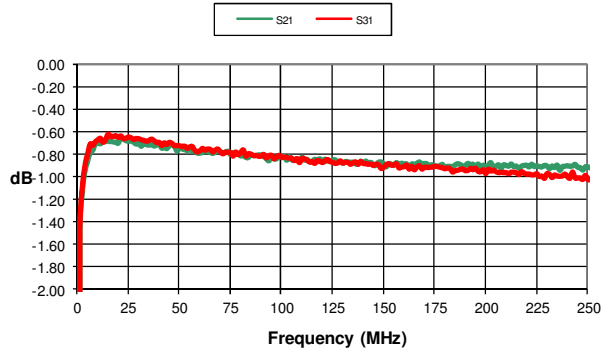

Amplitude Balance

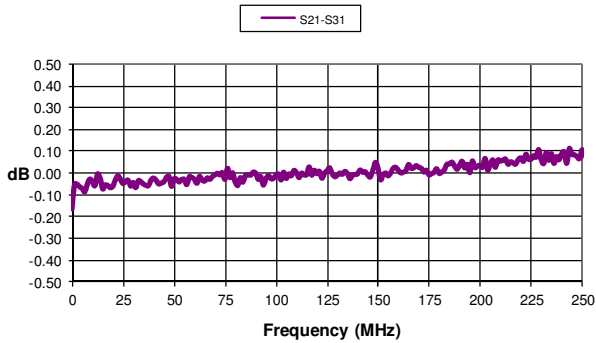

Phase Balance

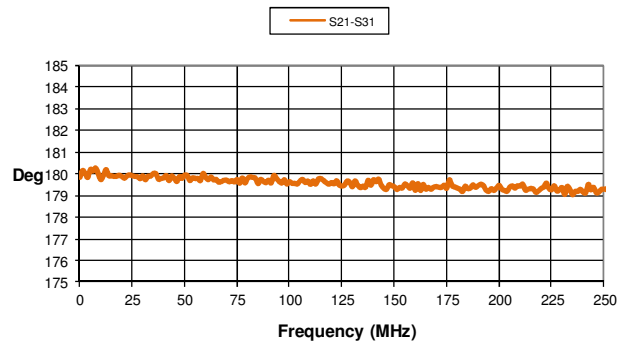

Pin Out

Pin	Function
1	Secondary
2	Secondary CT
3	Secondary Dot
4	Primary Dot
5	Primary

S20 Package Drawing

Dimensions in inches (millimeters)

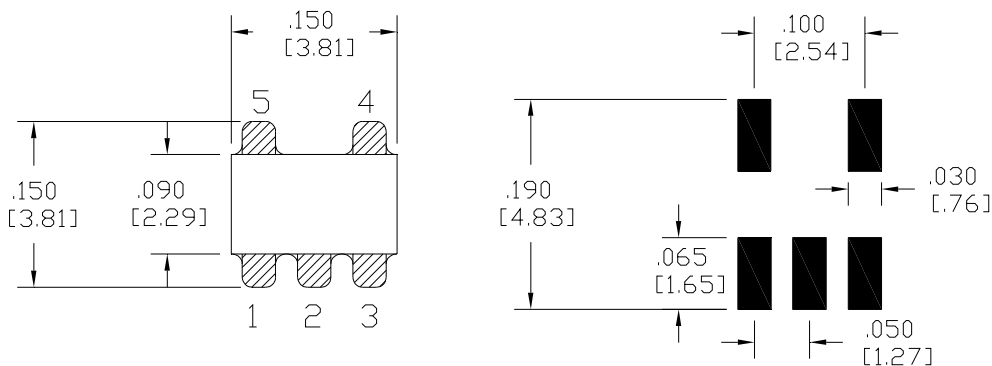

PCB FOOTPRINT

